

Doc. 573.419.050 Date/Datum/Fecha : 26/06/13 Annule/Cancel/ Ersetzt/Anula : 09/11/12	Modif. /Änderung : # moteur / motor 044 855 600 → 144 855 600	Pièces de rechange Spare parts list Ersatzteilliste Piezas de repuesto
--	---	---

MOTEUR A AIR, modèle 340-2 EOS	AIR MOTOR, model 340-2 EOS	#
LUFTMOTOR, Modell 340-2 EOS	MOTOR DE AIRE, tipo 340-2 EOS	144.855.600

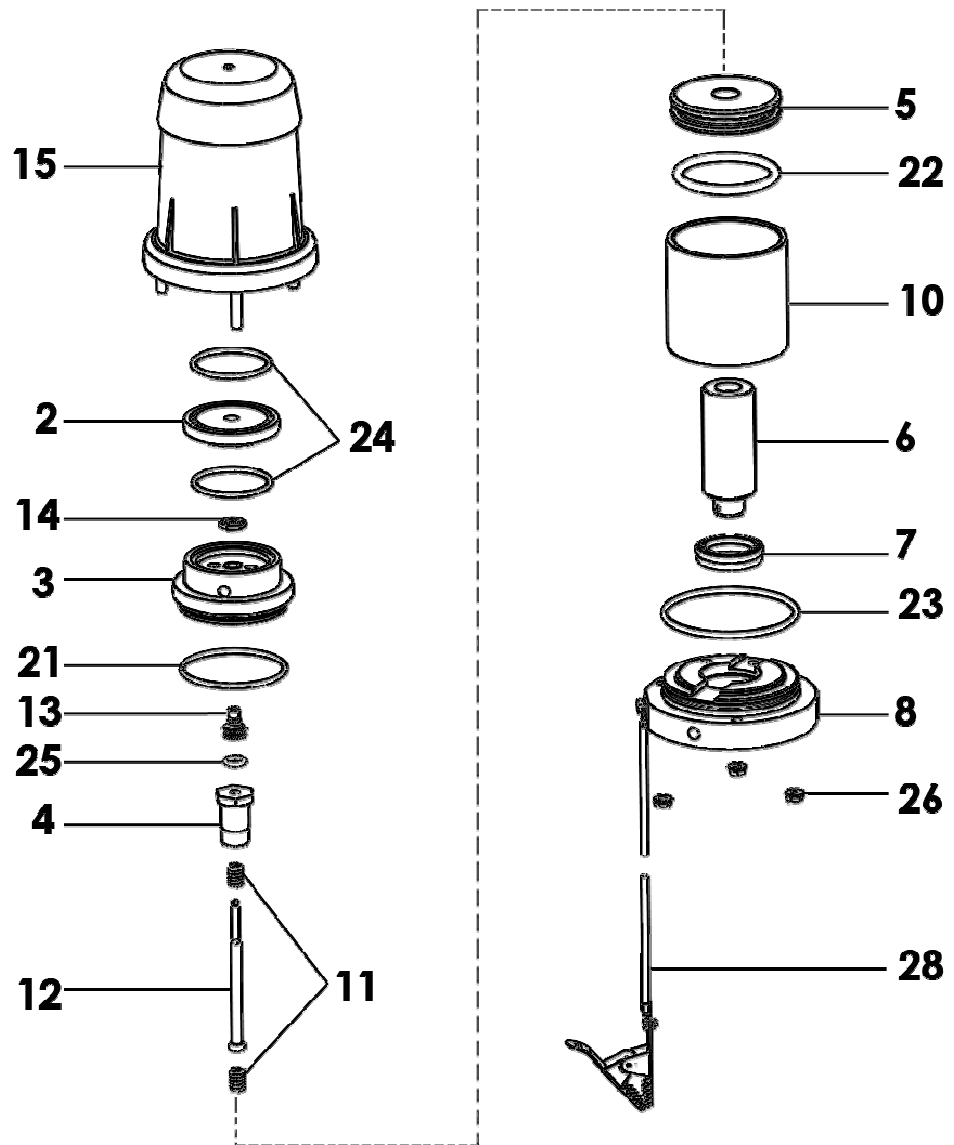

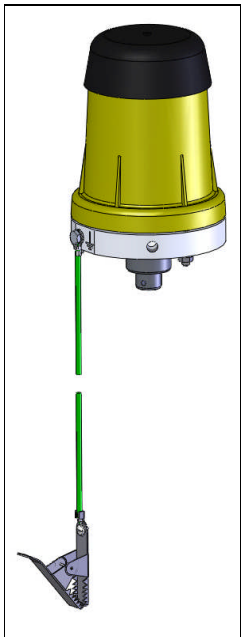

IMPORTANT : Respecter le **couple de serrage de 4mN maxi** sur les écrous (26).
Comply with the **maximum screwing torque of 4 mN / 2.95 ft/lbs** on the nuts (26).
Den Anziehmoment von 4 Nm maximal für die Muttern (26) entsprechen.
Cumplir con el par de apriete de **4mN maxi** en las tuercas (26).

Ind	#	Désignation	Description	Bezeichnung	Denominación	Qté
2	044 850 108	Couvercle	Cover, reversing body	Deckel	Tapa	1
*3	044 850 107	Corps inverseur	Reversing body	Umschaltblock	Cuerpo inversor	1
4	044 550 006	Vis piston air	Screw, air piston	Kolbenschraube	Tornillo pistón de aire	1
5	044 850 105	Piston air supérieur	Upper air piston	Luftkolbenoberteil	Pistón aire superior	1
6	044 850 102	Piston air inférieur	Lower air piston	Luftkolbenunterteil	Pistón aire inferior	1
7	109 210 401	Joint U (par 10)	U seal (pack of 10)	U-Dichtring (10er Pack)	Junta U (x 10)	1
8	044 850 101	Corps fond de cylindre	Lower support	Flansch	Tapa base cilindro	1
10	044 850 106	Cylindre air	Air cylinder	Luftzylinder	Cilindro aire	1
*11	144 855 698	Ressort (par 2)	Spring (pack of 2)	Feder (2er Pack)	Muelle (x 2)	1
12	044 850 103	Tige de commande assemblée	Control rod assembly	Steuerstange	Eje de mando equipado	1
13	044 940 051	Porte-joint	Seal holder	O-Ring-Halter	Porta- junta	1
14	044 550 013	Clapet	Valve	Umsteuerventil	Válvula de aire	1
*15	144 855 605	Cloche	Cover	Glocke	Campana	1
21	909 420 259	Joint O Ring	O Ring	Dichtring	Junta O Ring	1
22	909 130 438	Bague R36	Ring, R36	O-Ring R36	Junta R36	1
23	909 420 108	Joint O Ring	O Ring	O-Ring	Junta O Ring	1
24	909 420 220	Joint O Ring	O Ring	O-Ring	Junta O Ring	2
25	109 130 311	Bague R 9 (par 10)	Ring, R 9 (pack of 10)	O-Ring, R 9 (10er Pack)	Junta R 9 (x 10)	1
26	906 011 501	Ecrou M6	Nut, M6	Mutter, M6	Tuerca, M6	3
28	901 180 024	Câble de mise à la terre (Lg. 5 m)	Cable, ground (Length : 5m / 16.4 ft)	Erdungskabel (Länge : 5m)	Cable de puesta a tierra (5m de largo)	1

Ind	#	Désignation	Description	Bezeichnung	Denominación	Qté
*	144 850 150	Pochette de maintenance (rep . 7, 11, 14, 21, 22, 23, 24, 25)	Servicing kit (ind. 7, 11, 14, 21, 22, 23, 24, 25)	Servicekit (beinhaltet Pos. 7, 11, 14, 21, 22, 23, 24, 25)	Bolsa de reparación (ind. 7, 11, 14, 21, 22, 23, 24, 25)	1
*	144 855 696	Kit vis piston air + tige de commande (rep. 4, 12)	Screw, air piston + control rod kit (ind. 4, 12)	Kolbenschraube + Steuerstangekit (beinhaltet Pos. 4, 12)	Kit tornillo pistón aire + eje de mando (ind. 4, 12)	1
*	144 855 697	Kit inverseur (rep. 13, 14, 25)	Reversing kit (ind. 13, 14, 25)	Umsteuererkit (beinhaltet Pos. 13, 14, 25)	Kit inversor (ind. 13, 14, 25)	1

* Pièces de maintenance préconisées.

* Preceding the index number denotes a suggested spare part.

* Bezeichnete Teile sind empfohlene Ersatzteile.

* Piezas de mantenimiento preventivas.

N C : Non commercialisé.

N S : Denotes parts are not serviceable.

N S : Bezeichnete Teile gibt es nicht einzeln, sondern nur komplett .

N S : no suministrado.