

ENCLOSED TRACK CONVEYORS

ISO 9001
PACLINTM
OVERHEAD CONVEYORS
www.pacline.com

Signature Overhead System
The **PAC-LINE**TM

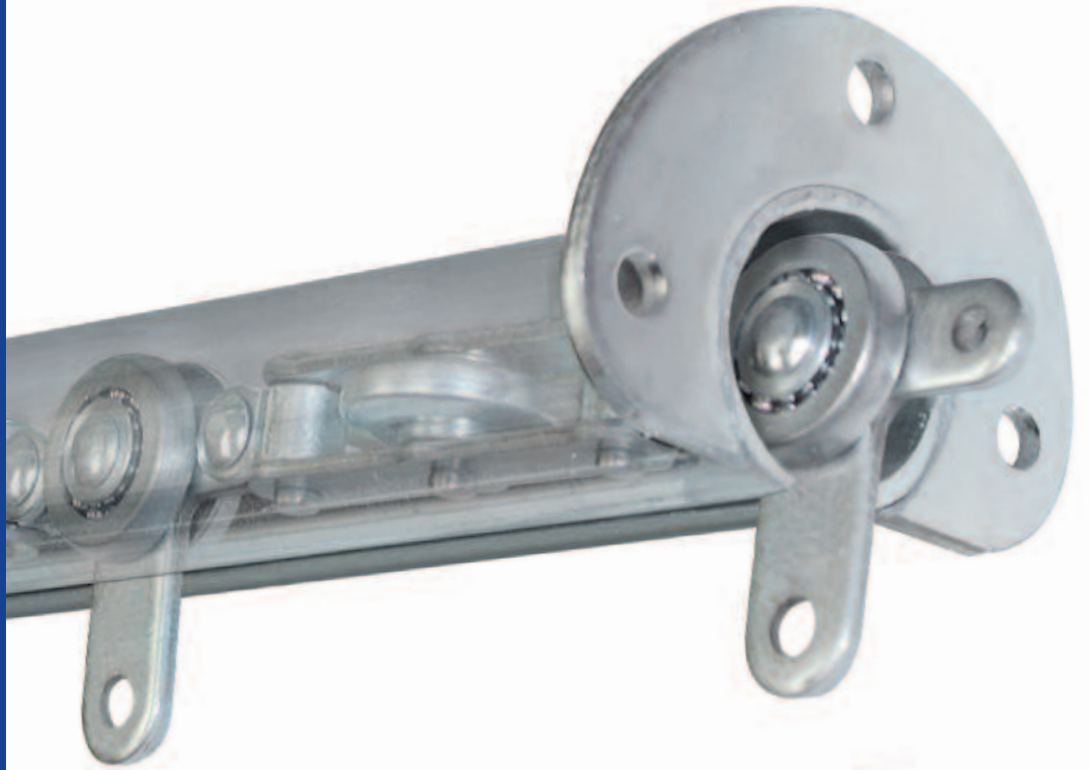

- **COMPACT**
- **MEDIUM CAPACITY**
- **ZINC PLATED**
- **MODULAR COMPONENTS**
- **BOLTED ASSEMBLY**

ENCLOSED TRACK CONVEYORS

ISO 9001™
PACLINE
OVERHEAD CONVEYORS

Model C-250

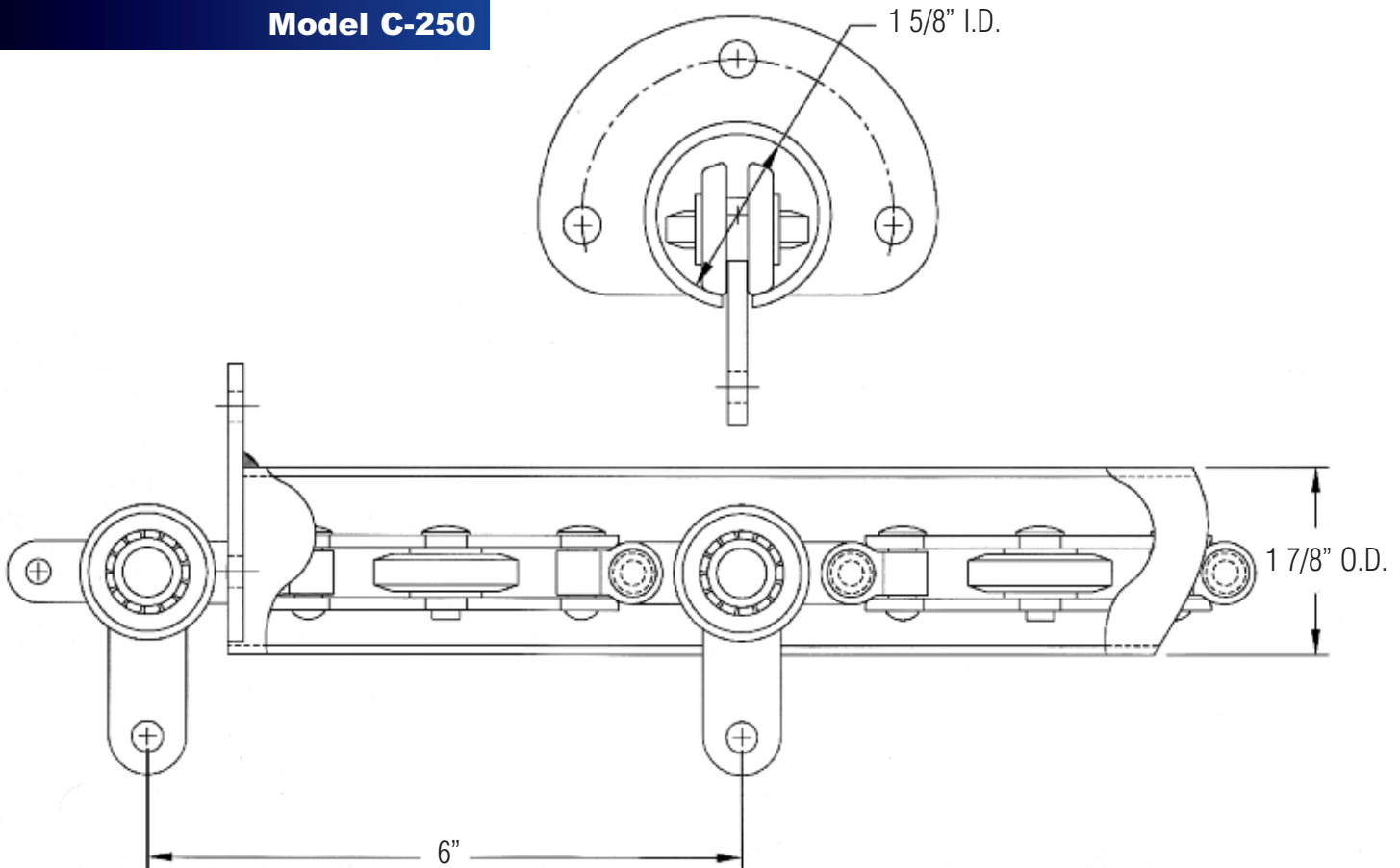

	C-250
Maximum Load Per Pendant	50 lbs.
Maximum Drive Pull	600 lbs.
Chain Breaking Load	3,700 lbs.
Nominal Chain Length Per Drive	600 ft.
Minimum Chain Friction Co-efficient	2.5%
Chain Pendant Pitch	6 inches
Standard Horizontal Curve Radius	24 inches*
Standard Vertical Curve Radius	24 inches
Maximum Drive Speed	60 F.P.M.
Maximum Incline Angle	90 degrees

* 9", 12" and 18" radius curves available with engineering approval

www.pacline.com • email: sales@pacline.com

CANADA/INT'L. SALES:

PACLINE CORPORATION

5890 Shawson Drive • Mississauga ON • L4W 3W5

Tel: 905.858.2330 • Fax: 905.858.2333

U.S.A. SALES:

PACLINE CONVEYORS, INC.

155 Great Arrow Ave • Buffalo • New York • 14207

Tel: 716.876.9250 • Fax: 716.876.9287