



The new P10 EASY Series applicators for hot-melt adhesives are the top innovation on the international market for their simplicity of use, production flexibility, maintenance costs, quick installation, ease of safety standards, exceptional reliability and full integration with any packaging line, granting the maximum operational flexibility. The new microprocessor controls all those operations necessary to the system proper running: thermo-regulation in all different system areas, programming control of 8 glue tracks for each of the 8 independent channels. Additional features are: Economy Function, Clock, Weekly Program, Max. temperature alarm, Sequential Heating of all channels and delay Temperature Set Point lock.

**NEW MELTING TANK**

A large loading inlet, opened on three sides, makes the 10 kg tank filling easier.

**REMOVABLE COVER**

Unique in its category, the cover is quickly removable in order to grant the maximum cleanliness and proper maintenance.

**LCD DISPLAY**

A new LCD display (specifically designed) graphically shows all the machine sections (tank, manifold, hoses and guns with respective parameters), allowing an immediate and extremely easy system programming also by unskilled operators, eliminating problems generated by codes and foreign languages to understand and meaning that the displays are all the same, independently of the country of use. A specific notification area controls the system status constantly and dynamically in all its operation phases. In case of eventual alarms or faults error messages are displayed.

**INNOVATIVE PROGRAMMING**

Another innovative feature of the new Easy Series is the "Rotary Switch": the selector through which it is possible, with extreme easiness, to program, modify and set section by section all those parameters intended for the system running.

**PRE-INSTALLED PNEUMATIC CONNECTIONS**

These allow a quick and safe system commissioning.

**ACCESSIBILITY**

All the internal parts of the applicator are easy to inspect thanks to a body system easy to open.

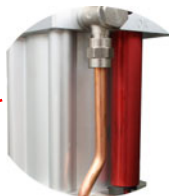
**NEW "PRECS" REVERSAL SYSTEM**

The innovative electronic cylinder "PRECS" allows a perfect and quick reversal preventing the lack of glue during this operation and granting the maximum reliability.

**HIGH PRECISION PNEUMATIC PUMP**

The dual effect piston pump with ratio of 14:1 is especially suitable for melting and application of adhesives and thermoplastic materials with a viscosity of up to 30,000 Cps. It is fully treated with a hard oxide coating and it is easy to remove in case of maintenance or replacement. The pump bottom can be inspected to check the suction ball status.

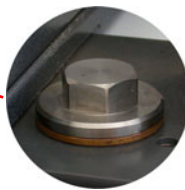
**GLUE FILTER**

Easy to access and replace, it ensures a better distribution of the adhesive preventing the nozzle clogging due to the presence of impurities in the adhesive.

**AUTOMATIC PRESSURE RELEASE VALVE**

Supplied as a standard, it ensures the utmost safety during the system use by automatically and safely releasing the adhesive pressure into the system in the event of an emergency.





## EASY SERIES P10



## DATA SHEET

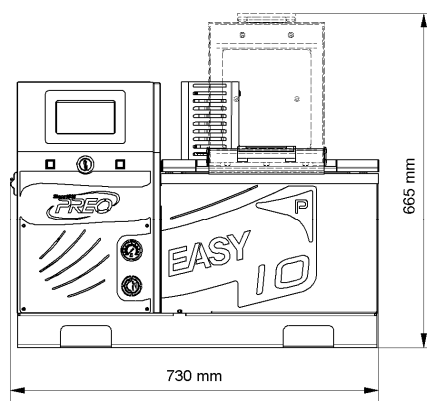
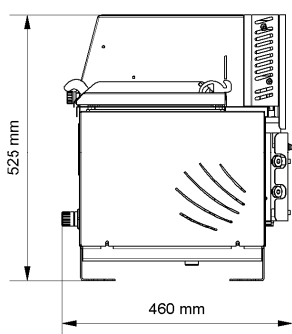
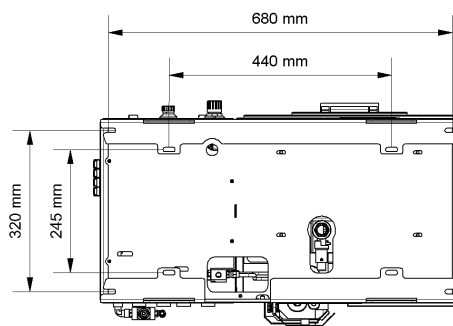
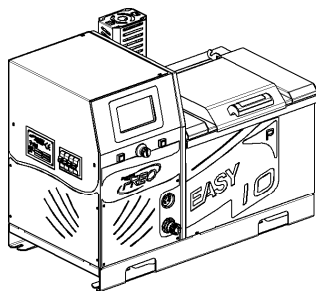

## GENERAL SPECIFICATIONS

ADHESIVE TYPOLOGY AND VISCOSITY	hot-melt up to 30.000 Cps
OPERATING TEMPERATURE	50°C±210°C (120°F±410°F) standard version - 50°C±230°C (120°F±450°F) HT high temperature version
HOSE/GUN CONNECTIONS	2, 4, 6, 8 (fitting thread 1/2"x20 UNF)
TANK CAPACITY	10 kg (22 lb)
MELTING RATE	11 kg/h (depending on used adhesive typology)
WEIGHT (EMPTY)	70 kg (155 lb)
MACHINE DIMENSIONS (L x H x W MM)	730 x 665 x 460 mm
TANK OPENING DIMENSIONS (MM)	178 x 184 mm
TANK	internally coated with PTFE scratch-resistant non-stick treatment, heated gills, quick drain valve and removable cover
MANIFOLD	coated with hard oxidation treatment and glue filter integrated
WARM-UP TIME	35'±40' starting from ambient temperature (0°C±45°C (32°F±113°F))
FASTENING	buttonhole for M8 screws

## ELECTRICAL SPECIFICATIONS

VOLTAGE	1/N/PE AC 230 V ±10% 50/60 Hz, 3/N/PE AC 400 V ±10% 50/60 Hz
POWER CONSUMPTION	3,5 kW (16 A) (no hoses and guns)

## MICROPROCESSOR SPECIFICATIONS

TEMPERATURE CONTROL	PT100 ±0,5°C (1°F) – RTD or Ni120 (on request)
MICROPROCESSOR TYPOLOGY	by graphic interface with LCD display 240x128 pixels LED back lighted and rotary switch programming selector
FUNCTIONS	Economy, Clock, Weekly Program, Maximum Temperature Alarm, Sequential Heating Zones
SAFETY	by-pass safety valve, over-temperature automatic protection, emergency stop input alarm, glue pressure release
OPTIONS	low level sensor, quick pressure release valve and flow regulation, integrated glue pattern control, automatic granule feeder

## PNEUMATIC PUMP SPECIFICATIONS

PUMP TYPE	double acting pneumatic piston pump ratio 14:1
REVERSING SYSTEM	electro-magnetic with end stroke sensors
MAXIMUM PUMP RATE	35 kg/h (depending on used adhesive typology)
WORKING PRESSURE	0,3±5,0 bar
MAXIMUM WORKING PRESSURE	55 bar

© Copyright 2009 PREO SRL - All rights reserved - Subject to change without advanced notice - Printed in Italy - Edition EN-100 EASY P10 - 07/10/2009

## PREO S.r.l.

Via Alessandro Volta, 7 • 20094 Corsico (MI) • Italia  
 tel. (+39) 02 48601260 • fax (+39) 02 4503323  
 www.preo.it • italia@preo.it • world@preo.it



YOUR  
QUALITY  
CHOICE